

SOLID STATE RELAYS  
RoHS Compliant  
AC TYPES

TYPE	WG A0			WG A3			WG A4	WG A8 6D		WG A8 8D	WG A8 10D	WG A8 6 05 PC	WG A8 6 05 LC	WG A8 6 10 LC
	Load Current	A rms	10	25	45	10	25	45	2	3	5			5
Surge Current	A peak	110	230	500	110	230	500	100		100			100	
I <sub>t</sub> for fusing	A <sup>2</sup> s	60	260	1250	60	260	1250	50		50			50	
Off-State Leakage current max.	mAeff	10			10			2	3	5			5	
Load Voltage range	V rms	WG A0 12Dxx : 48 - 480 WG A0 16Dxx : 48 - 660			WG A3 12D : 24(Z)/48(R) - 480 WG A3 16D : 24(Z)/48(R) - 660			(Z) 24 - 280 (R) 24 - 280	(Z) 24 - 280 (R) 24 - 280	(Z) 24 - 280 (R) 24 - 280	24 - 420		24 - 480	140 - 280
Peak off-state Voltage	V drms	1200			1200			600		600			600	
On-state Voltage	V peak	1.5			1.5			1.5		1.5			1.5	
Off-state (static) dv/dt min.	V / μs	1000			1000			500		500			500	
Snubber	Ohms ; nF	47 ; 10			47 ; 10			100 ; 10		47 ; 33			47 ; 10	
Output		THYRISTOR			THYRISTOR			TRIAC		TRIAC			TRIAC	
Supply Voltage	Vdc	-			-			-		-		3 - 32		5 - 24
Supply Current	mA	-			-			-		-		1		20
Control Voltage range	Vdc	3 - 32			3 - 32			3 - 32		3 - 32		0.6 - 40		0 - 10
Control Current max.	mA	30 (with LED)			25			14		14		22		22
Turn-off Voltage min.	Vdc	1			1			1		1		-		-
Input resistance	Ohm	Constant Current			Constant Current			Constant Current		Constant Current		-		10 Kohm
Resolution		-			-			-		-		Analogue		64 steps
Linearisation		-			-			-		-		None		By microprocessor
Turn-on time max.	ms	6 (at 24Vdc)			11 (Z) - 0.1 (R)			11		11 (Z) - 0.1 (R)				Controllable
Turn-off time max.	ms	11			11			11		11				11
Interlocking time	ms	40 - 80			-			-		-		-		-
Line frequency range	Hz	47 - 63			47 - 63			47 - 63		47 - 63			47 - 63	
Isolation between input / output	V rms	4000			4000			4000		4000			4000	
Isolation between in-output / base	V rms	2500			2500			-		-		-		-
Isolation resistance	Mohm	50			50			50		50			50	
Operating Temperature	°C	-20 +80			-20 +80			-20 +80		-20 +80			-20 +80	
Zero cross switching		-			WG A3 xxD xx Z			WG A4 6D 02 Z		WG A8 6D 0x Z		WG A8 8D 05 Z		WG A8 12D 05 Z
Random switching		Always Random			WG A3 xxD xx R			-		WG A8 6D 0x R		WG A8 8D 05 R		WG A8 12D 05 R
Heatsink I SSR 40°C	WG K1/100	-	-	-	-	-	-	-		-		-		-
	WG K2/100	8A	8A	8A	6A	6A	6A							6A
	WG K3/160	10A	22A	24A	10A	16A	17A							17A
	WG K4/160L	10A	25A	45A	10A	25A	42A							42A
	WG K5/80	-	-	-	-	-	-							-

Characteristics of Solid State Relays

- no mechanical parts
- galvanic separation between control and load circuit by opto-coupler
- semiconductor components like triacs, thyristors, alternators or MOS-FET's in the output

Advantages of SSR's against Electromechanical Relays

- nearly unlimited life expectancy
- low control power, direct interface to microcomputer or PLC
- no contact bounce
- no sparks
- no mechanical contact wear
- insensitivity to shock, vibration and mechanical forces as well as severe environmental conditions
- Comus thyristor SSR's are manufactured using DCB-technology (direct copper bonding) and are approximately 100 times more resistive to temperature cycles than conventional SSR's.

Application fields of Solid State Relays

- Medical equipment : heating control, motor control
- Security systems
- traffic control systems
- Office equipment & building infrastructure : elevators, escalators, automatic doors, copy machines, vending machines, industrial and domestic lighting control systems, light dimming systems, air conditioning, refrigeration, condensing fans, evaporator blowers, heating systems
- Lifts & industrial automation : temperature controls, test equipment, valves and motor control, motor reversing, soft start and stop
- Production machines : Ovens & furnaces, fryers, heaters, coffee machines, moulding and thermoforming machines, textile machines, conveyer systems, pumps and compressors, printing machines, test equipment, and industrial laundry machines.

COMUS solid state relays have been developed according to different regulations.

Information on VDE marking, approval nrs. 65641, 68302 and 70983, can be found doing an online search in the Catalog of VDE-Certified Products on [www.vde.com/VDE\\_PL\\_en](http://www.vde.com/VDE_PL_en).

Information on our UL/CSA recognized components, USR/CNR file nr. E103299 and E103300, can be found by checking the Online Certifications Directory on [www.ul.com/certifications](http://www.ul.com/certifications). Solid State Devices should be installed and wired according their intended use and Conditions of Acceptability. For details refer to the instruction manual or technical data on our website.

RoHS Compliant  
AC TYPES

TYPE	WG A5			WG 280										WG 280 D xxx-DUAL					WG 480 D / WG 660 D										WG 420 D ... Z - MR																	
	Load Current	A rms	10	25	40	10	25	40	50	75	90	110	125	10	25	45	10	25	40	50	75	90	110	125	10	25	45	50	75	90	110	125	10	25	45	50	75	90	110	125						
Surge Current	A peak	110	230	400	110	230	400	570	910	1090	1350	1590	110	230	500	110	230	500	570	910	1090	1350	1590	110	230	500	570	910	1090	1350	1590	110	230	500	570	910	1090	1350	1590							
I <sub>t</sub> for fusing	A <sup>2</sup> s	60	260	880	60	260	1250	1620	4150	5980	9100	12650	60	260	1250	60	260	1250	1620	4150	5980	9100	12650	60	260	1250	1620	4150	5980	9100	12650	60	260	1250	1620	4150	5980	9100	12650							
Off-State Leakage current max.	mAeff	6			12			12			12			6			12			WG 480 : 10 / WG 660 : 12										5																
Load Voltage range	V rms	24 - 280			24 - 280										24 - 280					WG 480 : 24(Z) / 48(R) - 480 WG 660 : 24(Z) / 48(R) - 660										150 - 420																
Peak off-state Voltage	V drms	600			600										600					WG 480 : 1200 / WG 660 : 1600										650																
On-state Voltage	V peak	1.5			1.5										1.5					1.5										1.5																
Off-state (static) dv/dt min.	V / μs	500			1000										1000					1000										500																
Snubber	Ohms ; nF	47;47			47;100			47;100			47;47			47 ; 100			47;47					47 ; 100					47 ; 22										-									
Output		TRIAC			THYRISTOR										THYRISTOR					THYRISTOR										THYRISTOR																
Supply Voltage	Vdc	-			-										-					-										20 - 32 (typ. 24 Vdc)																
Supply Current	mA	-			-										-					-										25 (@ 24Vdc)																
Control Voltage range	Vdc	WG A5 6D : 3 - 32			WG 280 D : 3 - 32										WG 280 D : 3 - 32					3 - 32										0 - 24 (active low input)																
Control Voltage range	Vac	WG A5 6A : 90 - 280			WG 280 A : 90 - 280										-					-										-																
Control Current max. without LED	mA	10			10										12					22										-																
Control Current max. with LED	mA	-LD : 22			-LD : 22										-					-										4 (@ 0Vdc)																
Turn-off Voltage min.	Vdc	1			1										1					1										Turn-on voltage <12 V, Turn-off voltage >19 V																
Input Resistance	Ohm	Constant Current			Constant Current										Constant Current					Constant Current										-																
Turn-on time max.	ms	11 (D-Z) - 33 (A-Z) - 0.1 (R)			11 (D-Z) - 33 (A-Z) - 0.1 (R)										11 (Z) - 0.1 (R)					11 (Z) - 0.1 (R)										11																
Turn-off time max.	ms	11 (D) - 33 (A)			11 (D) - 33 (A)										11					11										11																
Line frequency range	Hz	47 - 63			47 - 63										47 - 63					47 - 63										47 - 63																
Isolation between input / output	V rms	4000			4000										4000					4000										4000																
Isolation between in-output / base	V rms	2500			2500										2500					2500										2500																
Isolation resistance	Mohm	50			50										50					50										50																
Operating Temperature	°C	-20 +80			-20 +80										-20 +80					-20 +80										-20 +80																
Zero cross switching		WG A5 6D xx Z*			WG 280 x xx Z										WG 280 D xx Z					WG 480 D xx Z / WG 660 D xx Z										WG 420 D ... Z - MR																
Random switching		WG A5 6D xx R*			WG 280 x xx R										WG 280 D xx R					WG 480 D xx R / WG 660 D xx R										N/A																
Output Voltage max.	Vdc	-			-										-					-										30																
Output Current max.	mA	-			-										-					-										100																
Output Voltage drop max.	Vdc	-			-										-					-										1.3 @ 24Vdc / 100mA																
Heatsink I SSR 40°C	WG K1/100	10A	14A	16A	10A	18A	18A	20A	23A	25A	25A	25A	10A	11A	11A	10A	18A	18A	20A	23A	25A	25A	25A	10A	18A	18A	20A	23A	25A	25A	25A	10A	18A	18A	20A	23A	25A	25A	25A							
	WG K2/100	10A	17A	20A	10A	23A	23A	26A	31A	33A	33A	33A	10A	14A	14A	10A	23A	23A	26A	31A	33A	33A	33A	10A	23A	23A	26A	31A	33A	33A	33A	10A	23A	23A	26A	31A	33A	33A	33A							
	WG K3/160	10A	25A	31A	10A	25A	40A	50A	66A	74A	74A	74A	10A	25A	27A	10A	25A	40A	50A	66A	73A	74A	74A	10A	25A	40A	50A	66A	73A	74A	74A	10A	25A	40A	50A	66A	73A	74A	74A							
	WG K4/160L	10A	25A	40A	10A	25A	45A	50A	75A	90A	110A	125A	10A	25A	45A	10A	25A	40A	50A	75A	90A	110A	125A	10A	25A	45A	50A	75A	90A	110A	125A	10A	25A	45A	50A	75A	90A	110A	125A							
	WG K5/80	10A	24A	27A	10A	25A	34A	41A	51A	56A	56A	57A	10A	22A	22A	10A	25A	34A	41A	51A	56A	56A	57A	10A	24A	34A	41A	51A	56A	56A	57A	10A	24A	34A	41A	51A	56A	56A	57A							

\* = 8D version Also available

SSR's for AC loads

**WG A4 (PCB mounting)**  
Offers high component density on the PCB with a maximum load current of 2A

**WG A8 (PCB mounting)**  
Especially developed for PCB mounting with very small dimensions and load currents of 3A or 5A. There are types with 600 V peak-off-state voltage as well as types with 1200 V available.

The WG A8 is available in zero cross switching (Z-types) for resistive and capacitive loads or in random switching (R-types) for inductive loads.

**WG A8 PC / LC**  
The WG A8 series also offers phase controlled or linear controlled power for heaters or lighting up to 5A.

**WG A5 (Hockey Puck Housing)**  
Especially suited to switch resistive loads as in heaters and lamps.

**WG 280 (Hockey Puck Housing)**  
Designed to switch inductive loads like electric motors and valves (R-type) as well as resistive loads like heaters and lamps (Z-type).

**WG 480 / WG 660 (Hockey Puck Housing)**  
For switching applications in three phase systems, the WG 480 and 660 series offer excellent reliability due to high noise immunity (maximum peak-off-state voltage of 1200/1600 V) and extremely good dv/dt characteristics (partly with integrated overvoltage protection).

**WG 420 MR (Hockey Puck Housing)**  
Microprocessor controlled monitoring relay with LED-indication of the status and alarm output . Indicates open or short circuit, interruption, supply voltage and AC line voltage loss.

**WG A3 (Maxi Puck Housing)**  
This series is able to switch three phase loads with one control signal up to rated line currents of 45A and line voltages up to 480Vac. The WG A3 has high noise immunity and an internal overvoltage protection which becomes effective at 1000 V.

**WG A0 (Maxi Puck Housing)**  
This series is recommended for electronic motor reversing in three phase systems.  
Load voltages up to 480 Vac and load currents up to 45 A can be switched. A built-in interlocking circuit with a typical change over switching time of 60 +/- 20 ms prevents simultaneous switching-on of forward and reverse functions and prevents a short circuit between two phases. A LED indicates the forward and reverse function.

**SSR's for DC loads**

**WG F8**  
This PCB mounting type has a MOSFET output, suitable for resistive and capacitive loads. For inductive loads a protection circuit (diode or snubber) is recommended.

**WG F**  
This is the chassis mounting version with MOSFET output and load currents up to 30A.  
Types with IGBT output are available for high load voltages.

RoHS Compliant  
DC TYPES

TYPE	WG F 50 D 30										WG F 100 D 15					WG F 200 D 10					WG F 400 D 05					WG F 800 D 02					WG F 1600 D 01					
	Output	MOSFET										IGBT					MOSFET					MOSFET					MOSFET									
Load Current	A rms	30	15	10	5	10	8	10	5	3	1.5	80	50	35	15	150	80	100	50	35	15	80	100	50	35	15	80	100	50	35	15	80	100	50	35	15
Surge Current	A peak	80	50	35	15	150	80	100	50	35	15	80	100	50	35	150	80	100	50	35	15	80	100	50	35	15	80	100	50	35	15	80	100	50	35	15
Off-State Leakage current max.	mAeff	0.1										0.1					0.1					0.1					0.1									
Load Voltage range	Vdc rms	1-50										1-100					1-200					1-400					1-950									
Peak off-state Voltage	V drms	50										100					200					400					1200									
On-state resistance max.	mOhm	36										150					360					1100					-									
On-state Voltage	V peak	-										-					-					1.1 @ 4A					-									

HEATSINK DIMENSIONS

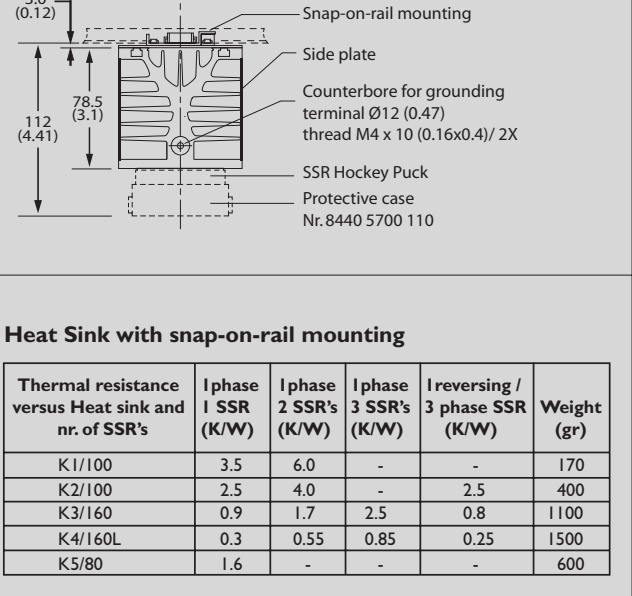
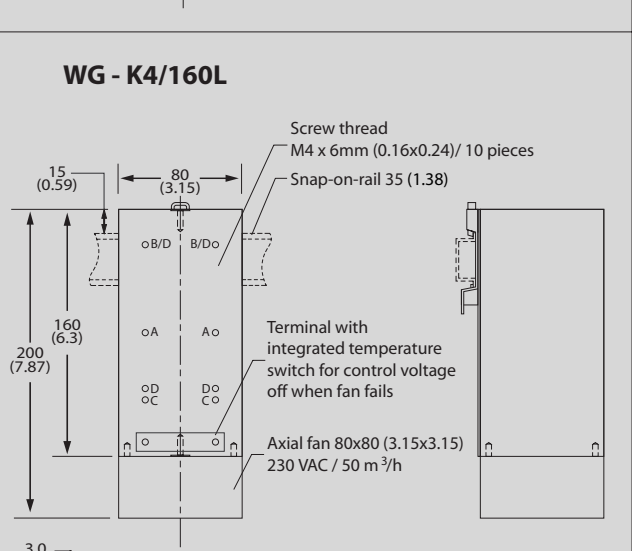
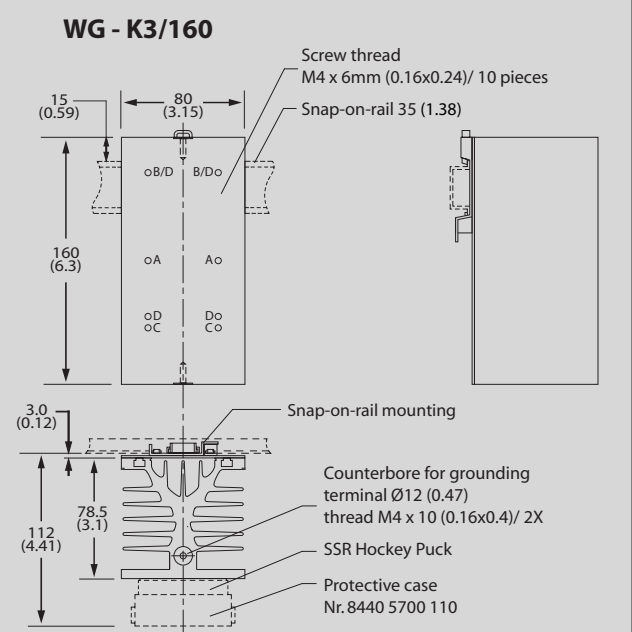
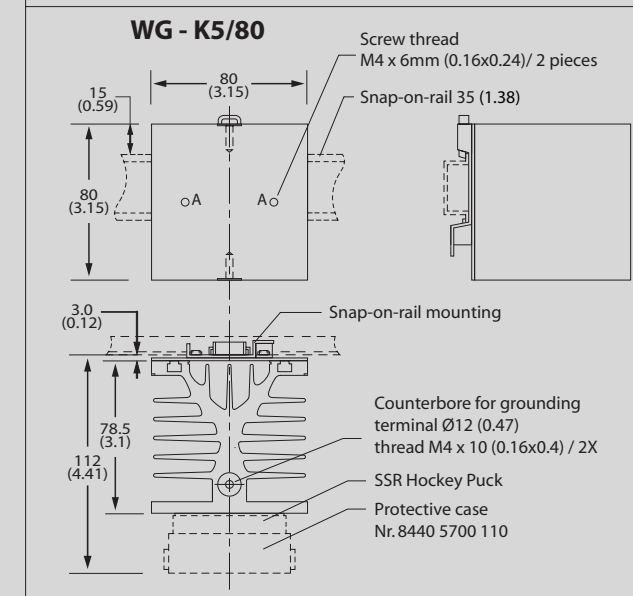
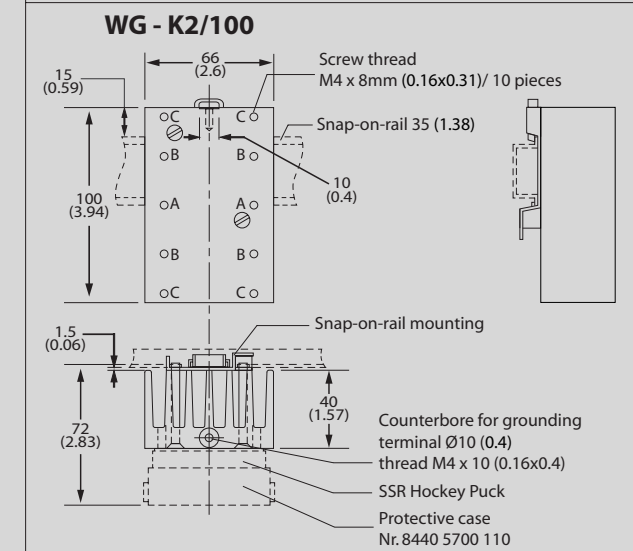
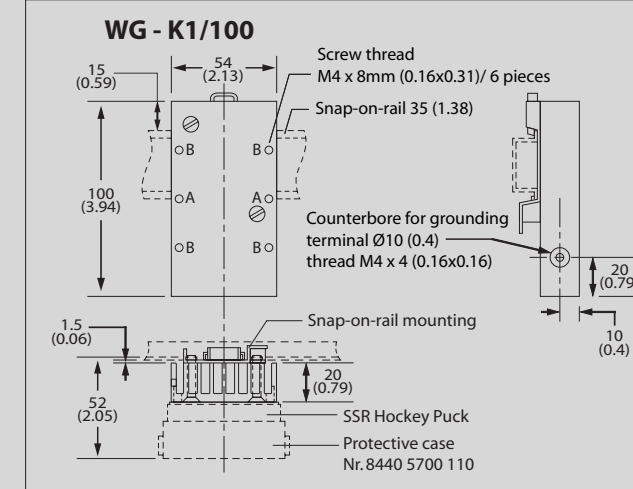

Thermal pads are available for Hockey Puck and Maxi Puck SSR's, having a thermal resistance of around 0.05 K/W @ 50psi. Excellent alternative to replace the thermal grease.

All dimensions are nominal, in millimetres unless otherwise stated. If further information is required, individual datasheets are available on our websites, and on CD. As part of the group's policy of continued product improvement, specifications may change without notice. Our sales office will be pleased to help you with the latest information on our products.

ORDERING AND PARTNUMBER SYSTEM

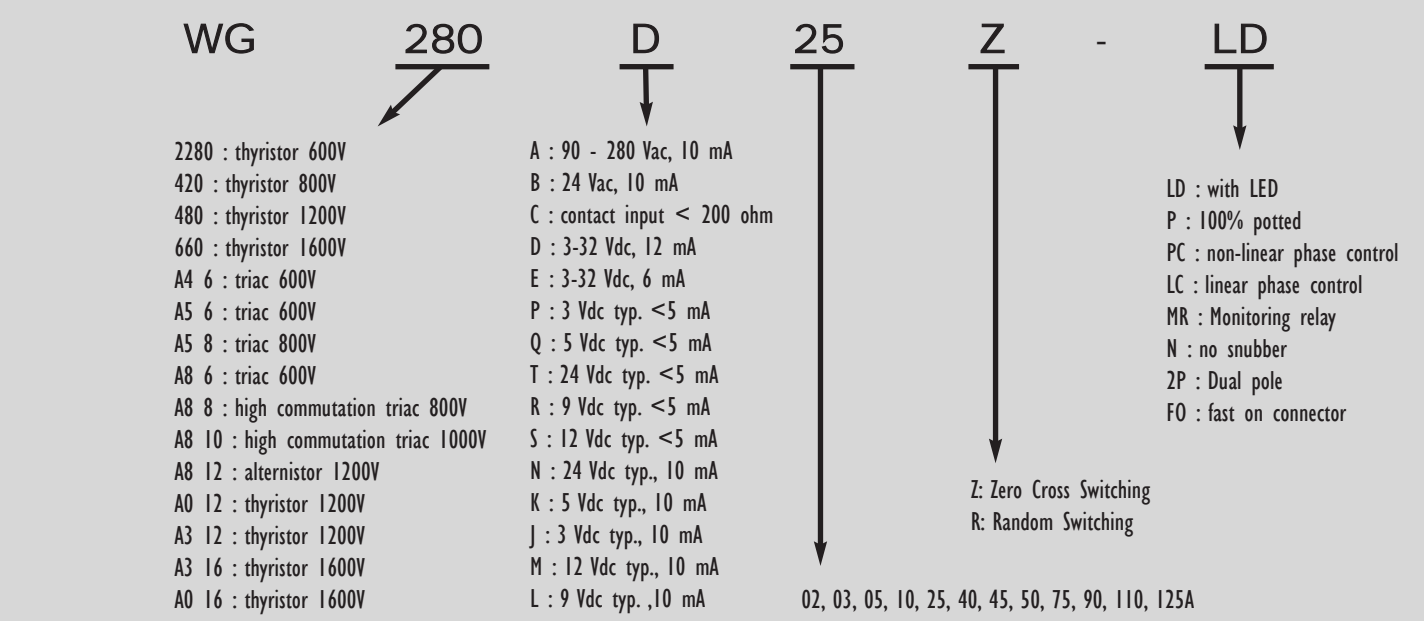

The Comus International group of companies consists of:

Comus International  
454 Allwood Road  
Clifton  
New Jersey 07012  
U.S.A

Tel: (1)973 - 777 - 6900  
Fax: (1)973 - 777 - 8405  
email: info@comus-intl.com  
internet: http://www.comus-intl.com

Assemtech Europe Limited  
Unit 7, Rice Bridge Industrial Estate  
Thorpe - Le - Soken  
New Jersey 07012  
Essex  
England  
CO16 0HL

Tel: +44 (0)1255 862236  
Fax: +44 (0)1255 862014  
email: sales@assemtech.co.uk  
internet: http://www.assemtech.co.uk

Comus Belgium BVBA  
Overhaamlaan 40  
B-3700 Tongeren  
Belgium

Tel: +32 (0)12 390400  
Fax: +32 (0)12 235754  
email: info@comus.be  
internet: http://www.comus.be

Comus International SARL  
Immeuble 'Les Juilliottes'  
31 Cours des Juilliottes  
F-94700 Maisons-Alfort  
France

Tel: +33 (0)1 43 96 86 10  
Fax: +33 (0)1 43 96 86 11  
email: info@comus.fr  
internet: http://www.comus.fr

Switching Technologies Gunther  
B-9, B-10, & C-1 Special Economic Zone (MEPZ)  
Kadapperi  
Tambaram  
Chennai 600 045  
India

Tel: +91 44 22628093  
Fax: +91 44 22628271  
email: stgtd@eth.net

Comus Electronics and Technologies  
India Private Limited  
No 26, Crescent Park Street  
T Nagar  
Chennai 600 017  
India

Tel: +91 44 42127124  
Fax: +91 44 42127125  
email: venkatraman@comus-intl.com  
syed@comus-intl.com  
internet: http://www.comusindia.com

We also have a large network of worldwide agents. These can be seen on any of our websites, or on our company profile brochure.

Solid State Relays



SOLID STATE RELAY DIMENSIONS

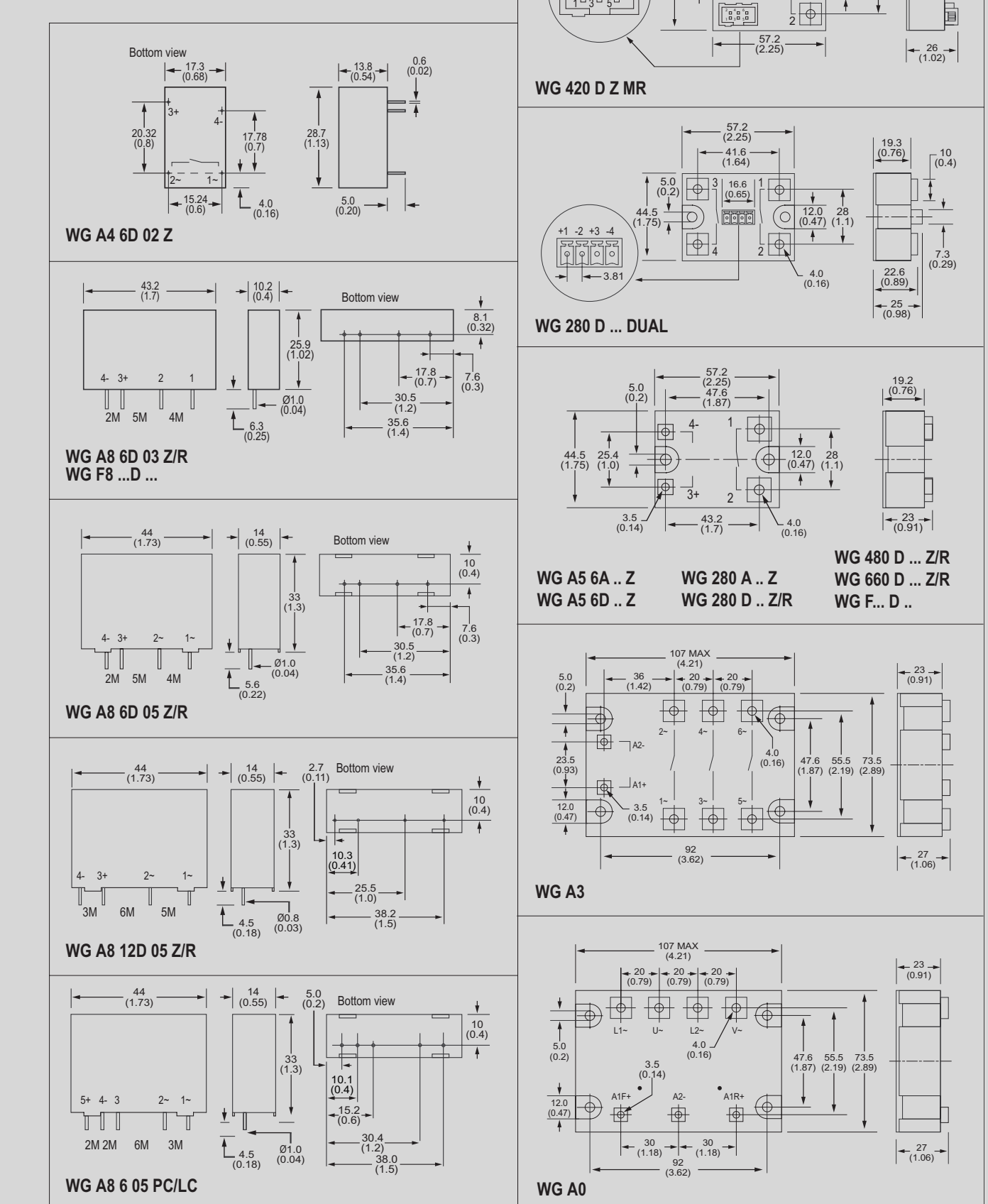

All dimensions are nominal, in millimetres unless otherwise stated. If further information is required, individual datasheets are available on our websites, and on CD. As part of the group's policy of continued product improvement, specifications may change without notice. Our sales office will be pleased to help you with the latest information on our products.