

INTRODUCTION

Heavy-duty wind sensor featuring superior mechanical resistance and great flexibility and a quality capable of competing with and even surpassing that of the best plastic and metal sensors on the market.

The design allows for extra electronics to be housed inside to provide additional features.

The bearings are made of stainless steel and lubricated with instrument oil..

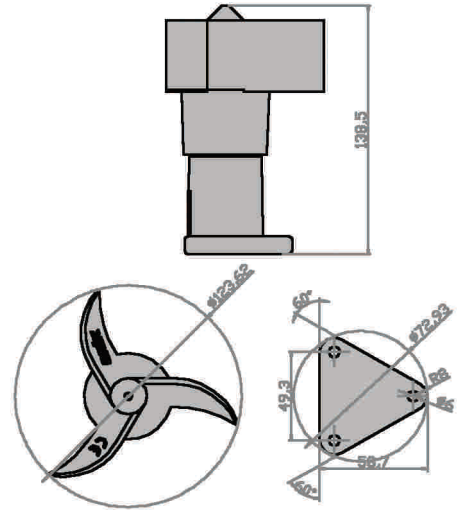

APPLICATIONS

The Anemo4403 has been designed for any system requiring wind speed data, including tower crane, greenhouse and wind turbine safety applications.

A common application consists of connecting the sensor to a tachometer (see our ref. TCA-200R), viewing the wind speed, and programming alarms to be triggered at various speeds, with the option of including an analogue output; or connecting to an Anemometer Alarm for Cranes (see our refs. SAG and VGT) or to a PLC or datalogger..

OPERATION

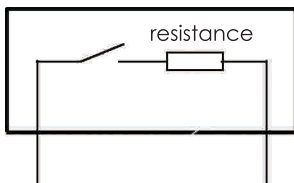

inputs / outputs

Supports wind speeds up to 200 km/h. The output is a voltage-free contact with a series resistance which opens and closes at a frequency that is directly proportional to the wind speed (see graph).

As an option, it can be manufactured with a Hall cell.

Wind speed ratio – output

The ratio is the result of multiplying wind speed in km/h times 1.05 to obtain the output in Hertz (pulses per second).

With a wind speed of 0 km/h the output is 0 Hz

With a wind speed of 100 km/h the output is 105 Hz.

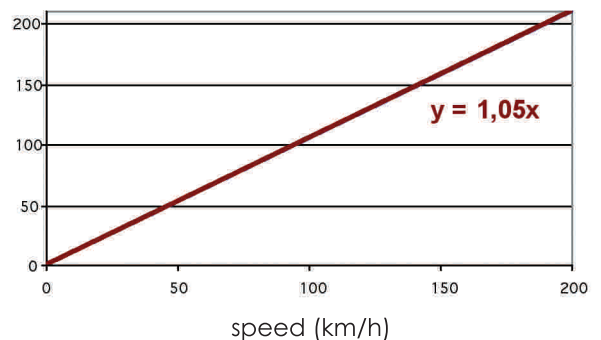

TECHNICAL CHARACTERISTICS

Power supply	5 a 15Vdc	IP level	IP65
Maximum intens.	15mA	Storage temp.	-40°C / +100°C
Range	2-200Km/h	Working temp. w/o ice	-20°C / +80°C
Accuracy	+ - 2%	Weight	154gr
Repeatability	0,5%	Weight with 20 m cable	1,265gr
Linearity	+ - 2%.		