

Solutions Seeking Problems.

MAGNASPHERE® 

TW-Series



This series is used in the security industry for door and window sensors in Closed loop alarm systems. It has a wider actuation zone in the X or Y axis than other Form A Magnasphere switches. Robust all metal construction is highly resistant to magnetic tamper and defeat, and permanent contact welding from power surges.

CONTACT CHARACTERISTICS

Contact Form: A (Normally Open-N.O.)
Contact Material: Gold/Gold
Initial Contact Resistance (Typical):
< 150 Milli Ohms
Contact Capacitance: < 1pf
Contact Ratings: 30 VDC @ 250ma
Contact Bounce* (Typical): < 10
milliseconds*. Recommended trial
de-bounce - 15 milliseconds (min.)
closed contact condition for logic state
changes - or 30 Hz low pass filter buffer
Minimum Breakdown Voltage (Typical):
300 VDC
Insulation Resistance (Typical):
> 5 Mega Ohms

OPERATION CHARACTERISTICS

Operate/Release Values:
See Switching Characteristics Table
Actuation Magnet Orientation:
Either Pole
Maximum Operating Frequency: 20 Hz
Mounting Position: Any Plane
Operating Temperature: -40°C to +150°C
Shock (Switch Damage): > 100 G's
Vibration: 10-15 G's (80-450 Hz)
(Higher Values Available)

GENERAL CHARACTERISTICS & INFORMATION

Construction: Non-Ferrous Metal Housing,
Compression Seal Hermetically Sealed,
Protective Gas Atmosphere, Precious
Metal Plated Spherical Magnet Contact.

Soldering Guidelines: 600° F (315° C)
Temperature iron for 5 sec. (max.). Do
not solder within 1/8" (3 mm) of glass
seal. Lead pins precious metal plated
for enhanced solderability.

Termination Polarity Guidelines: Polarity
selection is non-critical, though some

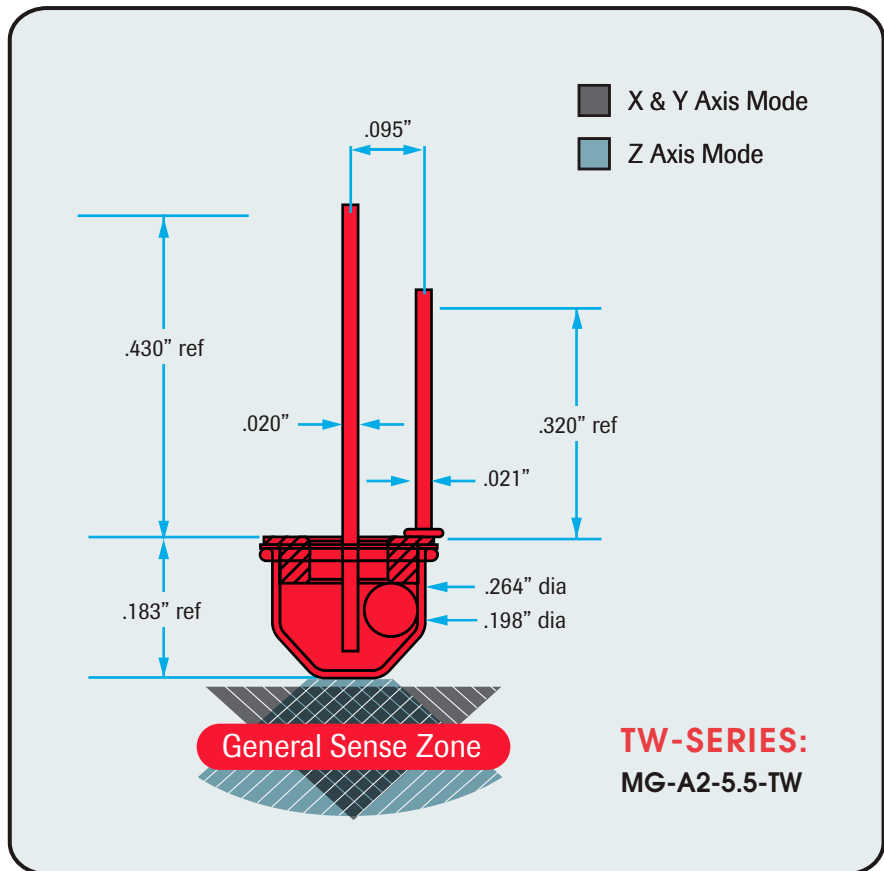

life gain may be realized by center pin
as cathode on logic loads, but center
pin as anode on larger loads.

Leadwire Cutting / Bending Guidelines:
Cut length has no effect on magnetic
OP/REL values. Shearing action type
cutters are recommended, but end nippers
and side cutters are NOT recommended.
Metal style seals are extraordinarily
rugged, but the bending of unsupported
lead wire pins adjacent to the glass seal
is not recommended (i.e. when bending

use the support of some type of parallel
jaws spaced away from the glass seal to
grip the lead wirepins while bending the
pins' free ends, so no bending strains
are imposed on the glass seal.

Other Comments: Ferromagnetic materi-
als and strong Electromagnetic devices
proximate to the switch or its actuator
magnet may adversely affect expected
OP/REL switching values. Experimenta-
tion is recommended to investigate
areas of concern.

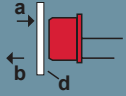
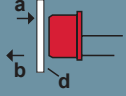

The Most Advanced and Effective Magnetic Sensor

		SWITCHING CHARACTERISTICS		AIR GAP DISTANCE		
		POSITION	TYPICAL	MIN	MAX	
MG-A2-5.5-TW Digikey Part#: 735-1003-ND 	(a) Leads Horz. "CLOSED" (b) Leads Horz. "OPEN"	.577"	.462"	.692"	NEO 35 MAGNET TARGET 0.5" L x .375" Dia	
		.713"	.610"	.817"		
MG-A2-5.5-TW Digikey Part#: 735-1003-ND 	(a) Leads Horz. "CLOSED" (b) Leads Horz. "OPEN"	NOT RECOMMENDED			FERROUS METAL TARGET EG: C1010 Low Carbon 1.0" L x 1.0" W x .0625" Dia	

TW-Series

Switching characteristics the target moves closer (a), this normally open switch will CLOSE at the air gap distance (d), and OPEN when the target moves away (b).

ABOUT MAGNASPHERE

MAGNASPHERE® Corp. is a privately held company founded in 2002, with the purpose of providing superior performing magnetic switch and sensor technology to the industrial/commercial OEM and security markets. MAGNASPHERE's patented, award-winning technology establishes new standards for magnetic switch performance while providing an affordable and more effective alternative to other magnetic switch technologies.

Learn more: Visit us at www.MAGNASPHERE.com.



PATENTED DESIGN

MAGNASPHERE® products are covered by one or more of the following U.S. and international patents:

- #5332992 #5530428 #5673021
- #5880659 #5977873 #6087936
- #6506987 #6603378 #6803845
- #7023308 (Patents Pending)

MAGNASPHERE® NOTICE OF LIMITED LICENSE AND RIGHTS: (Security Applications)
 The purchase of MAGNASPHERE® switches provides the purchaser and the purchaser's customers with a limited right and license to make, use, offer for sale, and sell security devices, each making use of a single MAGNASPHERE® switch; however, this limited right and license does not extend to and specifically excludes security devices making use of two or more MAGNASPHERE® switches that cooperatively monitor a single area or location.

INDUSTRY AWARDS

- Best of Show Award:
ISC Expo
- Gold Award
Sensor Technology:
Sensors Expo
- Best Intrusion
Detection:
ISC Expo